

Spring Lock Washer - IS 3063, DIN 127 Bv

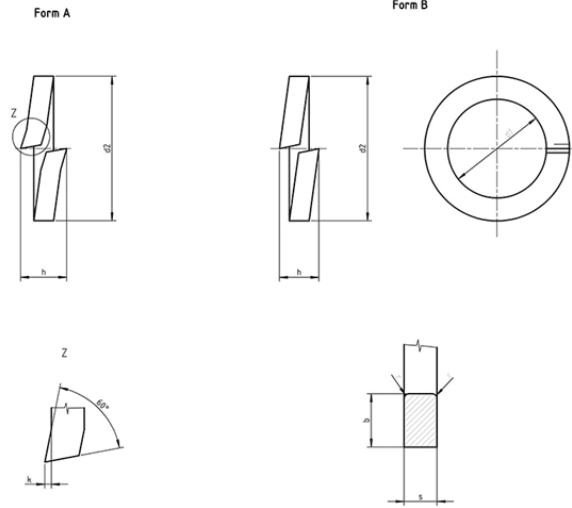

Form B: Washer with Flat Ends

Material: Carbon Spring Steel
Hardness: 44 to 52 HRC

Finish: As per requirement

Nominal Size	d1		d2 Max	b		s		r	k	h2		For Bolt Nut or Screw Size
	Basic	Tol		Basic	Tol	Basic	Tol			Min	Max	
2	2.1	+0.3	4.4	0.9	+0.1	0.5	+0.1	0.1	-	1	1.2	M2
2.2	2.3		4.9	1		0.6		0.1	-	1.2	1.4	M2.2
2.3	2.6		5.1	1		0.6		0.1	-	1.2	1.4	M2.5
3	3.1		6.2	1.3		0.8		0.2	-	1.6	1.9	M3
3.5	3.6		6.7	1.3		0.8		0.2	0.15	1.6	1.9	M3.5
4	4.1		7.6	1.5		0.9		0.2	0.15	1.6	2.1	M4
5	5.1	+0.4	10.2	1.8	+0.15	1.2	+0.15	0.2	0.15	2.4	2.8	M5
6	6.1		11.8	2.5		1.6		0.3	0.2	3.2	3.8	M6
7	7.1		12.8	2.5		1.6		0.3	0.2	3.2	3.8	M7
8	8.2		14.8	3		2		0.5	0.3	4	4.7	M8
10	10.2	+0.6	18.1	3.5	+0.15	2.2	+0.15	0.5	0.3	4.4	5.2	M10
12	12.2		21.1	4		2.5		1.0	0.4	5	5.9	M12
14	14.2	+0.8	24.1	4.5	+0.2	3	+0.2	1.0	0.4	6	7.1	M14
16	16.2		27.4	5		3.5		1.0	0.4	7	8.3	M16
18	18.2		29.4	5		3.5		1.0	0.4	7	8.3	M18
20	20.2	+1.0	33.6	6	+0.2	4	+0.2	1.0	0.4	8	9.4	M22
22	22.5		35.9	6		4		1.0	0.4	8	9.4	M24
24	24.5		40	7		5		1.6	0.5	10	11.8	M27
27	27.5		43	7		5		1.6	0.5	10	11.8	M30
30	30.5	+1.2	48.2	8	+0.25	6	+0.25	1.6	0.8	12	14.2	M33
33	33.5		53.2	10		6		1.6	0.8	12	14.2	M36
38	36.5		58.2	10		6		1.6	0.8	12	14.2	M39
39	42.5		61.2	10		6		1.6	0.8	12	14.2	M42
42	45.5		71.2	12		7		2	0.8	14	16.5	M45
45	49	+1.5	75	12	+0.25	7	+0.25	2	0.8	14	16.5	M48
48	53		83	12		7		2	0.8	14	16.5	M52
52	57		87	14		8		2	1	16	18.9	M58
56	61		91	14		8		2	1	16	18.9	M60
64	65		95	14		8		2	1	16	18.9	M64
72	73		103	14		8		2	1	16	18.9	M72
76	77		109	14		8		2	1	16	18.9	M78
80	81		111	14		8		2	1	16	18.9	M80
90	91		121	14		8		2	1	16	18.9	M90
100	101		131	14		8		2	1	16	18.9	M98